

INTRODUCTION

Thank you for acquiring our Hope Technology Slick Chain Guide STD version (Standard) proudly designed, built and tested in Barnoldswick, England. This Chain Guide has been designed, developed and extensively tested through riders and customer feedback to combat issues known with current Chain Guides. If this product is installed correctly it will dramatically reduce the chances of your chain derailing from your front chainring. Every component has been optimised to give a light weight yet robust product from the CNC'd backplates, guide plates and bash rings, to the stainless steel fasteners.

CHAINLINE

This chain device has been designed to work with the chainline between 47mm - 50mm. This is calculated between the centreline of the frame and centre of the chainring (see figure 1.). Both the width of the frame, length of bottom bracket and mounting position of the chainring all have an effect on the chainline. You must ensure this is correct before continuing with the installation.

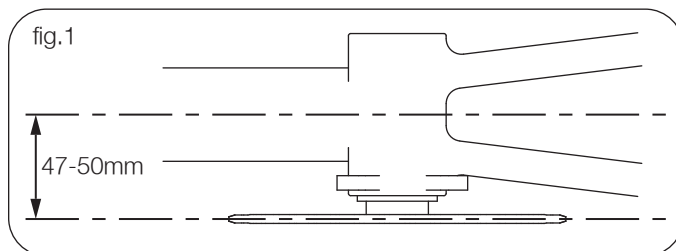

BOX CONTENTS & TOOLS REQUIRED

See reverse of sheet for full exploded view of box contents and tools required to fit this chainguide.

INSTALLATION

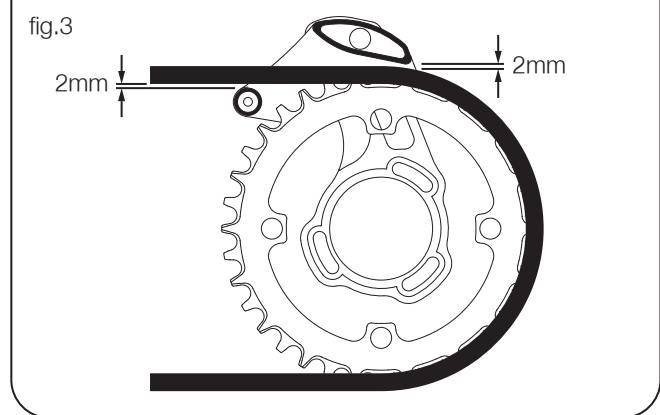
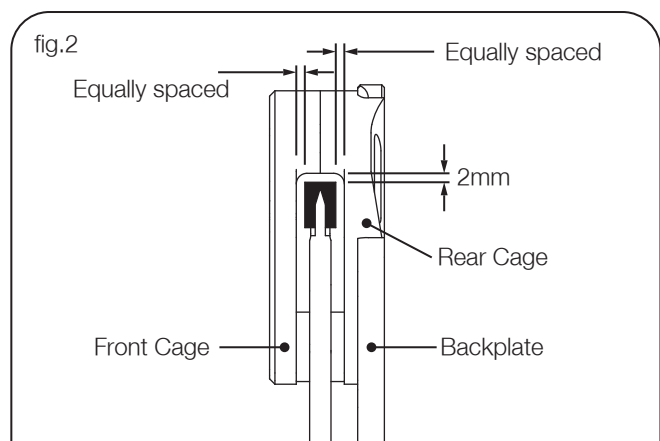

- Remove first the front mech from your frame if present.
- Remove the chain off the front chainring and at least the drive side crank arm.
- Ensure the ISCG mounting tabs on your frame are clean (including the threaded holes).
- Dismantle the upper cage of the chainguide from the backplate by removing the 20mm long dome head screw and remove the t-nut from the rear.
- Grease the M6 dome head screws and mount the chainguide backplate on the ISCG-OLD or ISCG-05 tabs of the frame, initially fitting the 2.5mm spacer between the backplate and the tabs. This should give a good starting point for the offset of the guide but can be adjusted later on by adding or removing spacers and washers. This is a trial and error process until you meet the optimum offset of your chainguide. Depending on the number of spacers and washers used, you will need either the 12mm or 16mm long M6 dome head screws. Lightly nip the screws to stop the backplate rotating.
- Re-install your crank arm following manufacturer recommendations, and place your chain onto the chainring.
- Set your chain to the smallest chainring on the rear cassette.
- Dismantle the upper rear cage from the upper front cage of the chain guide by removing the 18mm long cap head screw. Then re-assemble the cage around the chain (encapsulating it) torquing the screw up to 1 N.m.
- Now loosely fix the cage assembly back on to the backplate using the 20mm long dome head screw, 1.6mm washer and special t-nut. Slide the cage down the backplate until it is approximately 2mm away from the chain (see figure 2.). Once in position torque the dome head screw to 2-3 N.m.
- Only at this stage will you be able to see if your backplate is offset correctly. The spacing on either side the chain in relation to the front and back cage should be equally spaced (see figure 2). If not, you will need to swap the spacers (provided with this guide) between your back plate and ISCG tabs on your frame until the desired spacing is achieved.
- Loosen the 3x dome head screws holding the backplate to the frame and rotate the guide until the damper is approximately 2mm away from the chain (see figure 3.). Then hold the chainguide backplate in position and alternately tighten the 3x M6 dome head screws to 8-9 N.m.
- If set up correctly the chain should not touch any part of the guide resulting in a slick friction free setup.

WARNINGS

- Only to be installed on ISCG-OLD or ISCG-05 frame mountings.
- Do not modify the chainguide. Any modifications could lead to premature failure.
- Check the screws are torqued to the correct setting prior to every ride.
- Excessive torque on the screws may lead to the product being damaged.
- Only use the original bolts provided as these have been specifically designed and selected for the application.
- We recommend you have a qualified bike mechanic fit this guide if you are not confident with the installation.

WARRANTY

All Hope Technology components are covered for one year from original date of purchase against manufacturer defects in material and workmanship. Proof of purchase is required. Products must be returned to the original place of purchase or to Hope Technology to process any warranty claims. Please print and fill the "goods returned form" found on the 'Tech Support' section of our website should you wish to send a product back. This warranty does not cover any damage caused through misuse or failing to comply by the recommendations in this manual. This warranty does not affect your statutory rights.

- Tools Required:
- Crank removal tool
 - Torque wrench
 - 4mm Allen key
 - 3mm Allen key

